

ENERGY SQUARE

RECESSED DOWNLIGHT RANGE

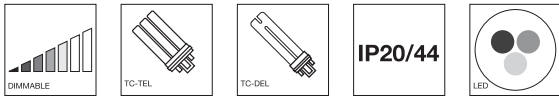

- IP20/44
- Fabricated Square Body
- Highly Polished Reflector
- Selection of Attachments
- High Frequency Control Gear
- Complete with Plug & Socket
- Adjustable Side Arm Suspension Brackets
- Longlife 50,000 hrs Fluorescent Lamps
- LED Option

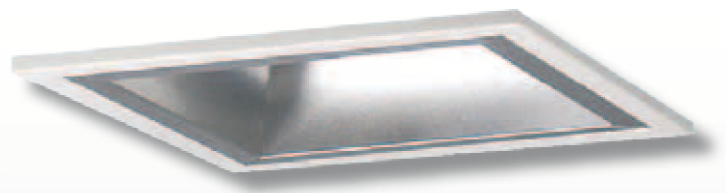

DESCRIPTION

High quality compact fluorescent recessed downlight range offering a variety of bezel attachments, white, chrome, gold or steel etc. LED options & long life fluorescent options.

APPLICATION

Commercial Applications, Prestige Offices, Foyers, Showrooms, Corridors, Retail Stores etc

RANGE AVAILABLE

Catalogue No.	Description	Weight (Kg)	Dimensions
NRGQ118	1x18w HF TC-DEL	1.5 Kg	
NRGQ218	2x18w HF TC-DEL	1.5 Kg	
NRGQ126	1x26w HF TC-DEL	1.5 Kg	
NRGQ226	2x26w HF TC-DEL	1.5 Kg	
NRGQ132	1x32w HF TC-TEL	1.5 Kg	
NRGQ232	2x32w HF TC-TEL	1.5 Kg	
NRGQ142	1x42w HF TC-TEL	1.5 Kg	
NRGQ242	2x42w HF TC-TEL	1.5 Kg	

LED Versions (Please refer to website for current technical specification)

Wattage	No LED's	mA	Lms	Weight (Kg)
NRGQ16wLED	60	500	1500	1.5 Kg
NRGQ23wLED	60	700	2100	1.5 Kg
NRGQ26wLED	72	700	2500	1.5 Kg

Available in colour temp 3000/4000/5000K
Note EM3 version c/w 4 x 1 Watt LED

Suffix (see attachments opposite page)

/EM3 3 hour Remote Maintained Emergency
/LIFE Long Life Fluorescent option

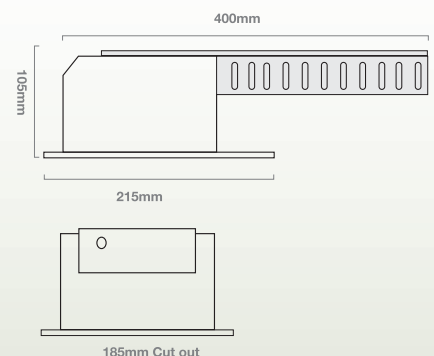

ENERGY SQUARE ACCESSORIES

NRGQ ACCESSORIES

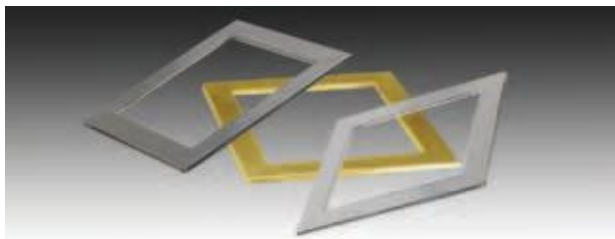

Bezel Attachment

QCB	Chrome Bezel	0.1 Kg
QGB	Gold Bezel	0.1 Kg
QSB	Steel Bezel	0.1 Kg



Cat 2 Attachment

QC2	CAT2 Louvre	0.1 Kg
-----	-------------	--------



IP 44 Attachment

Q44C	Clear	0.09 Kg
------	-------	---------



IP 44 Frosted Attachment

Q44F	Frosted	0.09 Kg
------	---------	---------



Floating Attachment

QFR1	Frosted outer with hollow centre	0.2 Kg
------	----------------------------------	--------



Wallwasher Attachment

QFA	Wall washer	0.06 Kg
-----	-------------	---------



Frosted/Clear Full Disc Attachment

QFC1	Outer frosted inner clear	0.3 Kg
------	---------------------------	--------

